

**Appendix 2 to the Yearly Market Agreement and Hourly Market Agreement of
Frequency Containment Reserves**

Unofficial translation

Fingrid Oyj

**The technical requirements and the
prequalification process of Frequency
Containment Reserves (FCR)**

Valid from 25 February 2021

Table of contents

1	Introduction.....	2
2	Subjecting a Reserve Unit for prequalification.....	2
2.1	Prequalification process.....	2
2.2	Necessary documentation.....	4
2.3	Validity period of prequalification test.....	5
3	Technical requirements.....	5
3.1	Activation of Frequency Containment Reserve for Normal Operation.....	5
3.2	Activation of Frequency Containment Reserve for Disturbances.....	7
3.3	Activation capability.....	9
3.4	Re-activation of Frequency Containment Reserve for Disturbances.....	10
3.5	Requirements for measurements.....	10
3.6	Energy storage facilities.....	10
3.6.1	State of charge management in Frequency Containment Reserve for Normal Operation.....	10
3.6.2	Restoration of full activation capability in Frequency Containment Reserve for Disturbances.....	11
4	Execution of prequalification tests.....	11
4.1	Specification of reserve capacity.....	12
4.1.1	Verification of Frequency Containment Reserve for Normal Operation.....	12
4.1.2	Verification of Frequency Containment Reserve for Disturbances.....	13
4.2	Accuracy requirements concerning measuring and registering equipment.....	15
4.3	Measurement of sensitivity of load-frequency control.....	15
4.4	Issues to be taken into account in the measurement of power plant machineries.....	15
4.5	Prequalification tests of aggregated Reserve Units.....	16
4.6	Documentation of prequalification test results.....	17

1 Introduction

This document describes the prequalification process of Reserve Units offered for the maintaining of Frequency Containment Reserves (FCR) and the verification of compliance with the technical requirements concerning Reserve Units in accordance with article 155 of the Guideline on System Operation, Commission Regulation (EU) 2017/1485. The general requirements concerning Balancing Service Providers have been described in Fingrid's document "Terms and conditions for providers of Frequency Containment Reserves (FCR)".

The Frequency Containment Reserves include three reserve products, Frequency Containment Reserve for Normal Operation (FCR-N) and Frequency Containment Reserve for Disturbances Upwards (FCR-D up) and Frequency Containment Reserve for Disturbances Downwards (FCR-D down). The Frequency Containment Reserve for Normal Operation is a symmetrical product, in other words it must be possible to activate the reserve capacity both as upward balancing and downward balancing. Upward balancing means an increase in electricity production or a decrease in consumption, and downward balancing means a decrease in production or an increase in consumption.

2 Subjecting a Reserve Unit for prequalification

2.1 Prequalification process

The process illustrated in Figure 2.1 is followed in the prequalification of a Reserve Unit. Balancing Service Provider is responsible for carrying out the prequalification tests in accordance with Chapter 4 of this document and for delivering the required information (see item 2.2) within the prescribed deadlines. Fingrid is responsible for the verification of the information and measurement results within the deadline prescribed in the process chart and for informing Balancing Service Provider of the result of the prequalification process.

Fingrid has the right to send its representative to the prequalification tests. Balancing Service Provider is responsible for the costs caused by the carrying out of the tests and Fingrid only for its own personnel costs.

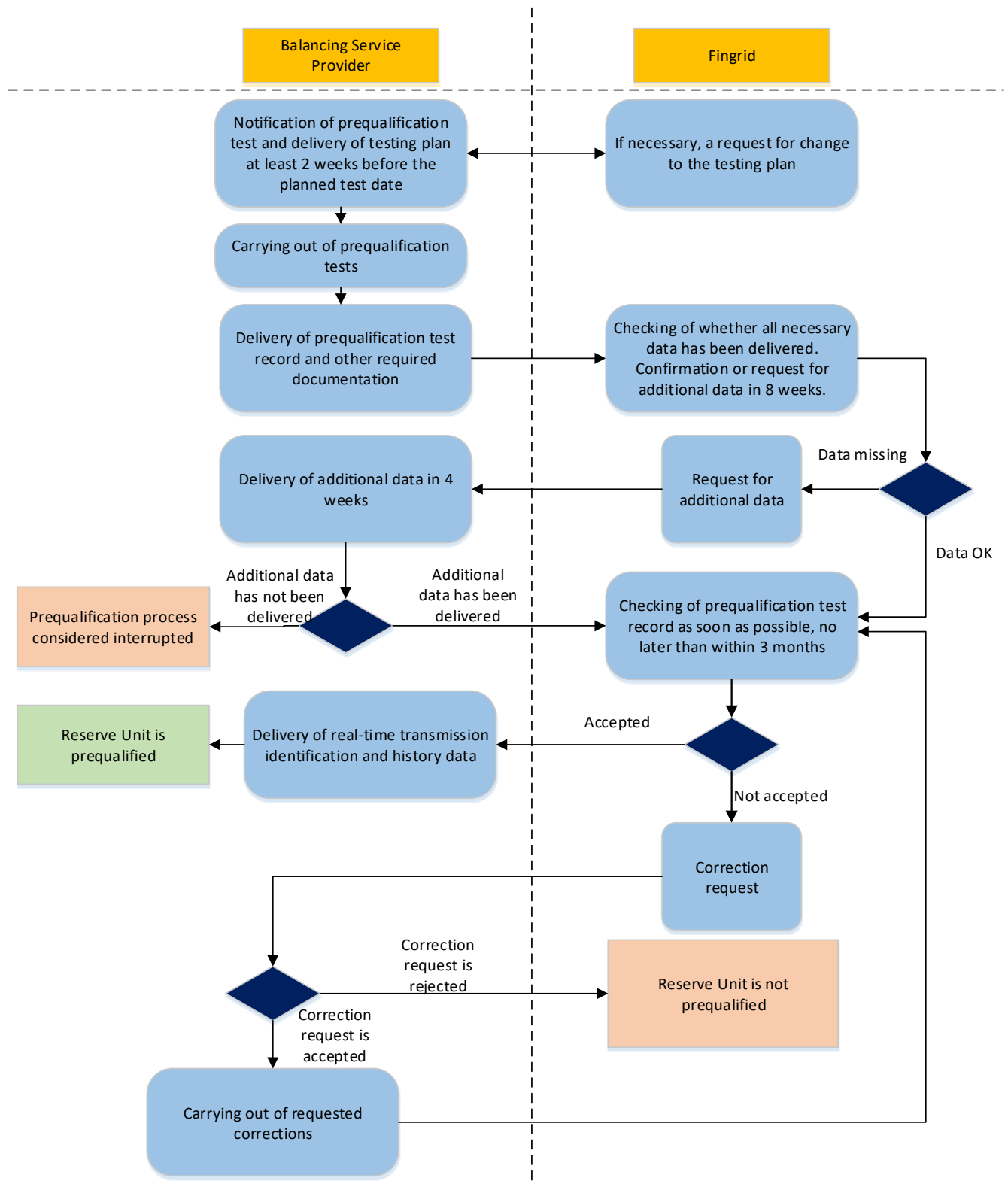

Figure 2.1 Progress of prequalification process

2.2 Necessary documentation

The prequalification test results shall be documented in a prequalification test record (see item 4.6), which shall be delivered to Fingrid after the prequalification tests.

Moreover, the following information shall be delivered of new Reserve Units, depending on the type of the unit:

Power plants:

- rated power (MW)
- maximum power (MW)
- head of hydropower plant (m)
- type and parameters of turbine governor.

Consumption:

- type of load such as industrial process (what kind of process?), lighting, heating
- maximum power (MW)
- technical description of the functioning of the control system.

Energy storage facilities:

- rated power (MW)
- energy capacity (MWh)
- upper and lower limit of charge level (MWh or %)
- technical description of the functioning of the control system including energy management if applicable.

For aggregated reserve units it is also required to provide a description of the aggregation system and data transfer between the centralized controller and the individual resources.

It is recommended that the above information be delivered before the prequalification test in so far as it is available.

The requirements concerning the reporting and follow-up of reserves have been described in Fingrid's document "Terms and conditions for providers of Frequency Containment Reserves (FCR)". A description of the calculation of real-time data and the identifier used in the sending of the real-time data shall be delivered in connection with the prequalification process of the Reserve Unit. The appropriate saving of history data shall be indicated by delivering history data for a period of at least one hour, during which the unit has participated in load-frequency control.

Only the prequalification test record, a sample of the history data and any changed information need to be delivered of a Reserve Unit whose prequalification test is renewed.

2.3 Validity period of prequalification test

The validity period of prequalification tests is 5 years from the test date. Prequalification tests carried out before 1 January 2019 have a validity period of 10 years. A prequalification test shall be renewed before the ending of the validity period. A prequalification test shall also be renewed whenever changes influencing reserve operation are carried out on the Reserve Unit, such as renewal of control equipment or change of control parameters.

3 Technical requirements

3.1 Activation of Frequency Containment Reserve for Normal Operation

The Frequency Containment Reserve for Normal Operation is a symmetrical reserve product. 100 per cent of the reserve capacity shall be activated as upward balancing, when the frequency is 49.9 Hz or less. Correspondingly, when the frequency is 50.1 Hz or more, 100 per cent of the reserve capacity shall be activated as downward balancing. In the frequency range of 49.9 to 50.1 Hz, the volume of the activated capacity shall be proportional to the magnitude of the frequency deviation.

As a result of a stepwise frequency change of 0.10 Hz, the control shall be activated in full in three minutes. The activation shall not be significantly and purposely delayed.

The maximum dead band in load-frequency control may be 50 ± 0.01 Hz. The activated reserve within the dead band is zero. Reserve Units, whose prequalification test was carried about before 1 January 2020, may continue to use a maximum dead band of 50 ± 0.05 Hz according the previous requirements, until their prequalification expires.

If a Reserve Unit is capable of controlling its power continuously, the control shall be linear within a frequency range of 49.9-50.1 Hz in accordance with Figure 3.1. Linear activation may be continued also outside this frequency range in accordance with the broken line in the figure. This shall be documented in the prequalification test record.

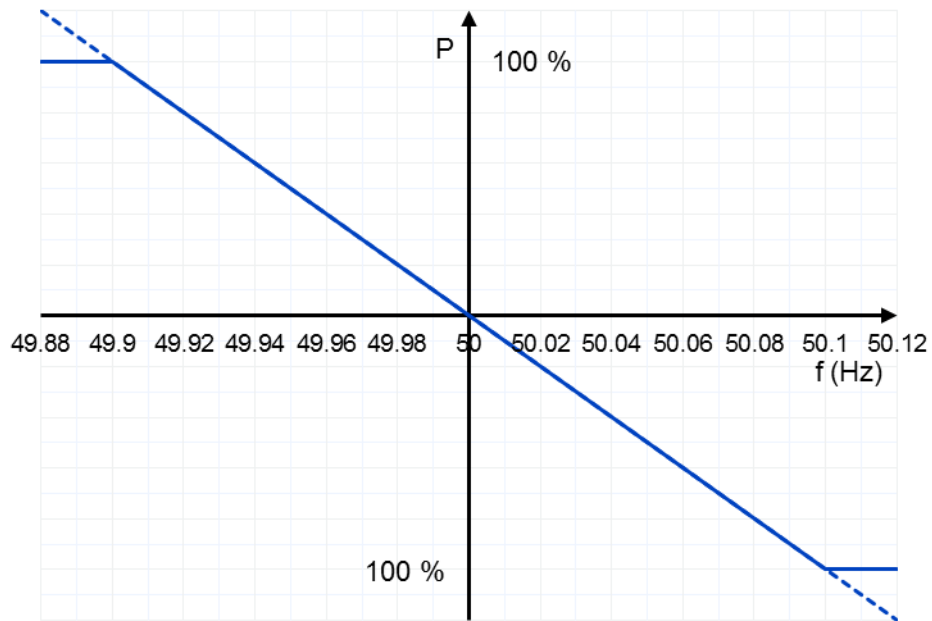

Figure 3.1 Linear control curve, FCR-N

The control curve of relay-connected Reserve Units shall be piecewise linear within a frequency range of 49.9-50.1 Hz. Activation shall take place within the blue area indicated in Figure 3.2. The red line in the figure indicates an example of a control curve that fulfils the requirements. The control curve shall be documented in the prequalification test record or in the description of the control system.

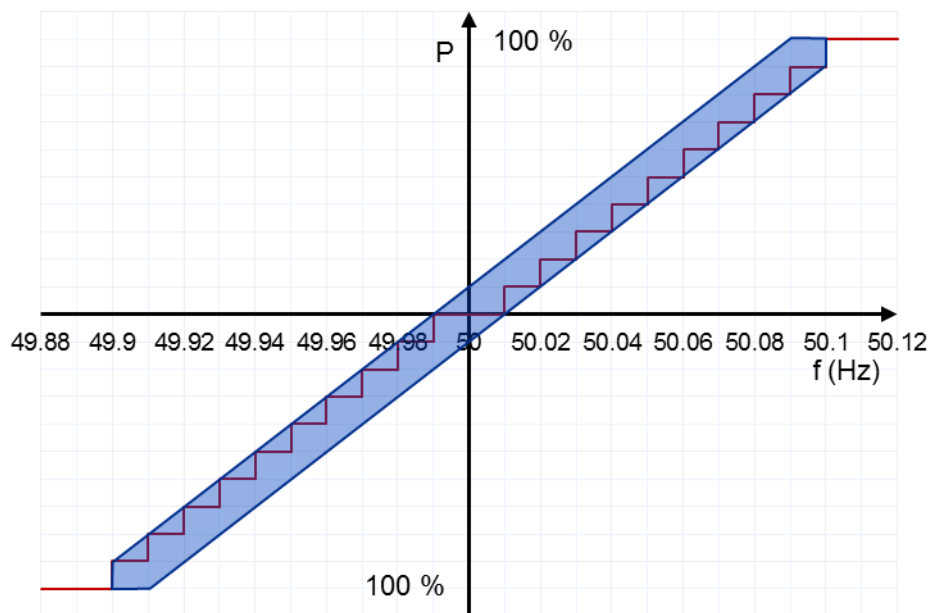

Figure 3.2 Piecewise linear control curve, FCR-N

3.2 Activation of Frequency Containment Reserve for Disturbances

With the Frequency Containment Reserve for Disturbances, the activation of the reserve capacity upwards shall begin when the frequency goes below 49.9 Hz. 100 per cent of the reserve capacity shall be activated, when the frequency is 49.5 Hz or less. In the frequency range of 49.5 to 49.9 Hz, the volume of the activated capacity shall be proportional to the magnitude of the frequency deviation.

With the Frequency Containment Reserve for Disturbances, the activation of the reserve capacity downwards shall begin when the frequency goes above 50.1 Hz. 100 per cent of the reserve capacity shall be activated, when the frequency is 50.5 Hz or above. In the frequency range of 50.1 to 50.5 Hz, the volume of the activated capacity shall be proportional to the magnitude of the frequency deviation.

At least 50 per cent of the Frequency Containment Reserve for Disturbances shall be activated in five seconds and 100 per cent shall be activated in 30 seconds as a result of a stepwise frequency change of 0.50 Hz. The activation shall not be significantly and purposely delayed.

If a Reserve Unit is capable of controlling its power continuously, the control shall be linear within a frequency range of 49.5–49.9 Hz in accordance with Figure 3.3. Linear activation may be continued also outside this frequency range in accordance with the broken line in the figure. This shall be documented in the prequalification test record.

The green control curve drawn in Figure 3.3 can be applied if the activation illustrated with the blue curve cannot be implemented with the controller.

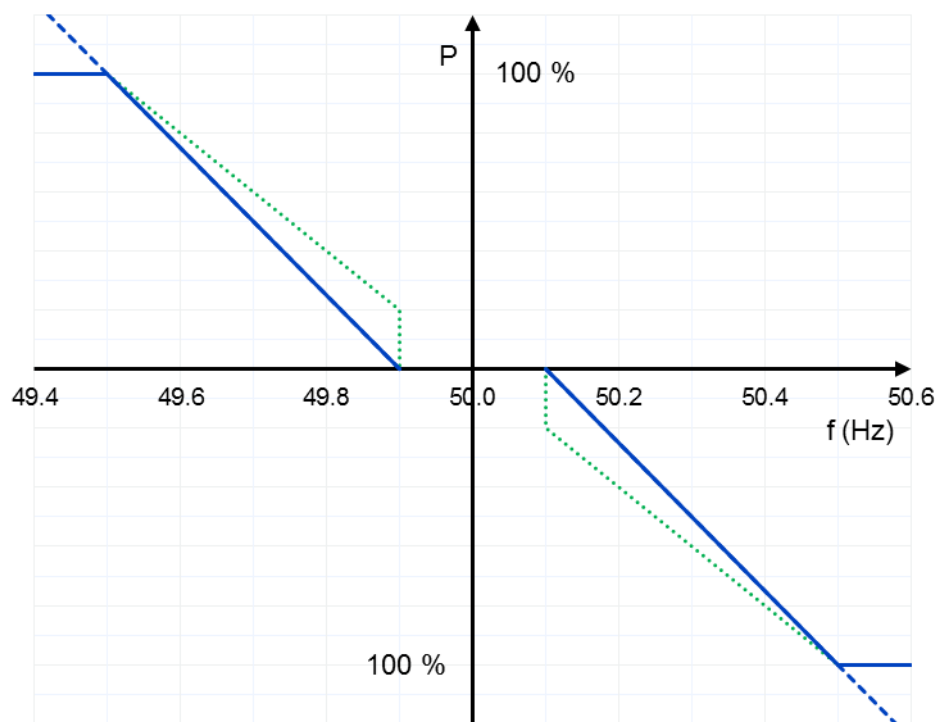

Figure 3.3 Linear control curve, FCR-D up and down

The control curve of relay-connected Reserve Units shall be piecewise linear. Activation shall take place within the blue area indicated in Figure 3.4. The red line in the figure indicates an example of a control curve that fulfils the requirements. The control curve shall be documented in the prequalification test record or in the description of the control system.

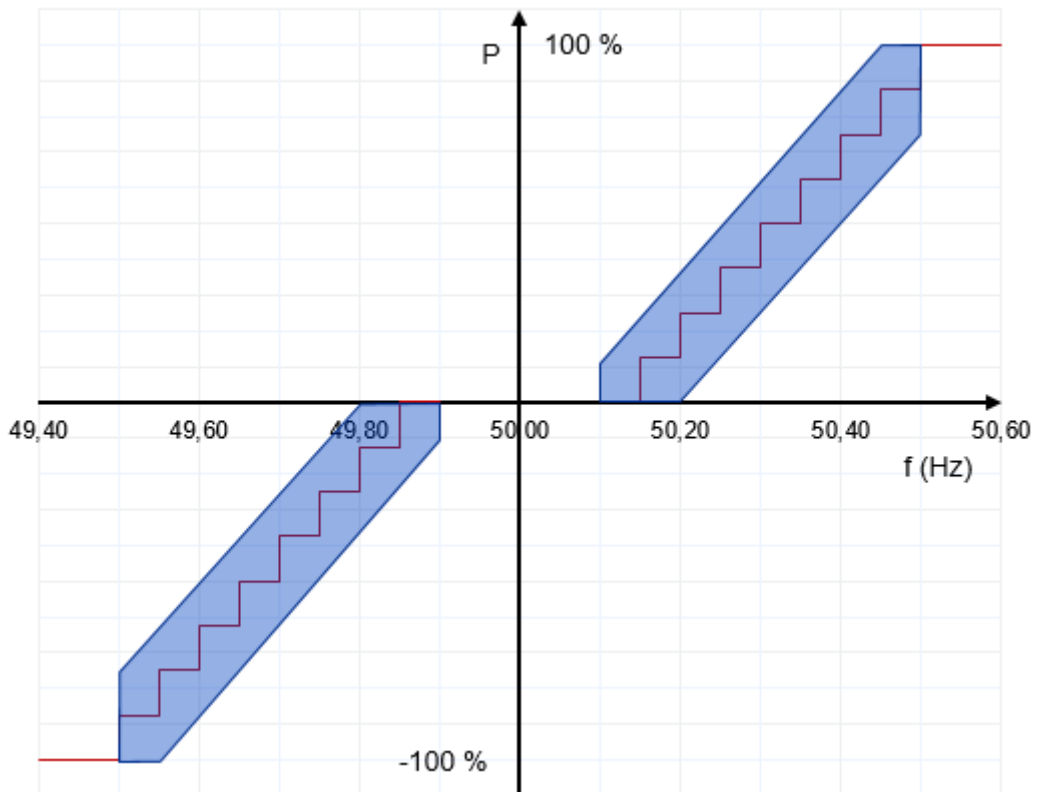

Figure 3.4 Piecewise linear control curve, FCR-D up and down

3.3 Activation capability

A Reserve Unit used for the maintaining of the Frequency Containment Reserve for Normal Operation and/or Frequency Containment Reserve for Disturbances shall be capable, apart from the exception stated below, of activating the reserve in full for the entire delivery period.

A Reserve Unit whose activation capability is limited shall be dimensioned so that the Reserve Unit is capable of continuous full activation of at least 30 minutes per direction (upwards and downwards regulation). A Reserve Unit that has a limited activation capability refers to a Reserve Unit whose energy reservoir may become completely empty in the event that the reserve capacity has to be activated in full for the entire duration of the delivery period. In terms of such Reserve Units, Balancing Service Provider shall determine in advance the factors that limit the activation capability and have the Reserve Unit accepted as a unit with limited activation capability. The above stated dimensioning requirement is a minimum requirement to provide reserves and does not guarantee the ability to maintain the reserve during the whole contracted delivery period.

3.4 Re-activation of Frequency Containment Reserve for Disturbances

A Reserve Unit used in the maintaining of the Frequency Containment Reserve for Disturbances shall be capable of re-activating the reserve capacity in full no later than 15 minutes from the previous activation.

3.5 Requirements for measurements

A provider of a Reserve Unit can measure the frequency used in the control from a point of its choice in the Finnish electricity system. The frequency measurement shall have an accuracy of at least 10 mHz and a resolution of 1 mHz.

The resolution of the active power measurement shall be 0.01 MW. The required accuracy depends on the rated power of the measurement according to Table 3.1.

Table 3.1 Accuracy requirement of power measurement

Category	Rated power	Max. inaccuracy
1	< 2 MW	± 5 %
2	2–10 MW	± 1 %
3	> 10 MW	± 0,5 %

For logging of history data as required in “Terms and conditions for providers of Frequency Containment Reserves (FCR)”, the sampling interval of the frequency and active power measurements can be maximum 1 s.

3.6 Energy storage facilities

All the general requirements laid down in this document apply to energy storage facilities. They are also subject to requirements concerning state of charge management.

3.6.1 State of charge management in Frequency Containment Reserve for Normal Operation

The power taken from the grid or fed into the grid by an energy storage facility that participates in the maintaining of the Frequency Containment Reserve for Normal Operation shall not be controlled in ways other than on the basis of frequency in accordance with reserve operation. This principle applies to the power and energy capacity of the energy storage facility in so far as the capacity has been reserved for the maintaining of the reserve, and is also valid within the dead band of load-frequency control.

The power and energy capacity of the energy storage facility that is not reserved for the maintaining of the reserve, may be used for state of charge management. The state of charge management shall not interfere with the activation of the reserve according to the control curve.

When an energy storage facility reaches the maximum or minimum charge level, it interrupts the activation of the reserve capacity until the direction of the frequency deviation changes or the activation capability is restored by state of charge management.

The minimum and maximum values of the charge level of an energy storage facility can be decided by Balancing Service Provider. The reserve capacity shall be designed so that the activation capability requirement specified under item 3.3 is fulfilled when the energy storage facility operates within the selected limits (such as at a charge level of 5-95 per cent).

3.6.2 Restoration of full activation capability in Frequency Containment Reserve for Disturbances

The recharging power of an energy storage facility that participates in the maintaining of the Frequency Containment Reserve for Disturbances shall be designed so that when the energy capacity of the energy storage facility runs out completely, the full activation capability is restored as soon as possible; however, no later than within two hours from the starting of recharging. The recharging of the energy storage facility shall be started as soon as the frequency is 49.9 Hz or more. If necessary, the reserve capacity shall be re-activated in accordance with the frequency also during recharging. When recharged from the electricity network, the rate of change of power shall be no more than $P_{FCR-D}/5$ min, where P_{FCR-D} is the prequalified reserve capacity. The principle of the activation of an energy storage facility and of the consequent recharging stage is illustrated in Figure 3.5. In accordance with the graph, the recharging power is raised by a ramp at the beginning of recharging until the desired recharging power value is reached.

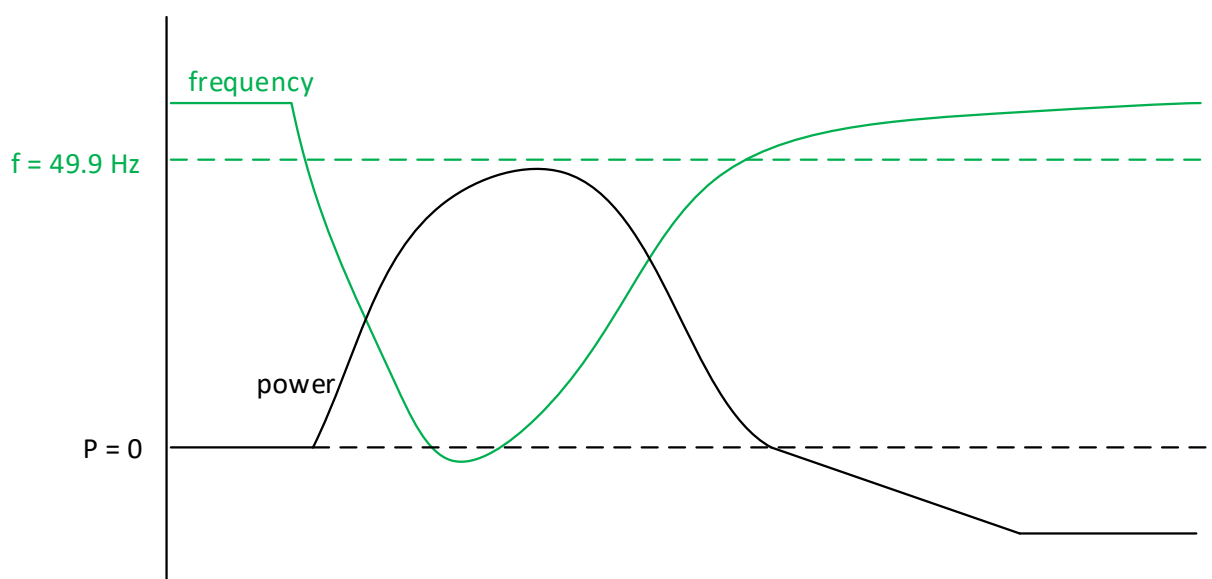

Figure 3.5 Recharging of energy storage facility in Frequency Containment Reserve for Disturbances

4 Execution of prequalification tests

Balancing Service Provider shall make sure that a Reserve Unit that contributes to the maintaining of the Frequency Containment Reserve for Normal Operation and Frequency Containment Reserve for Disturbances fulfils the technical requirements laid down in this document. The fulfilment of the requirements shall be verified by means of prequalification

tests that shall be carried out in a normal operating situation of the Reserve Unit. A number of control settings (for example different droop settings) can be specified for the Reserve Unit, and the functioning of all of these shall be verified by means of prequalification tests.

The Reserve Unit shall be synchronised to the electricity system during a prequalification test. Potential other controls affecting the active power or the activation of the reserve, such as automatic frequency restoration reserve (aFRR), shall not be in use. The frequency measurement of the network shall be replaced by a test signal in accordance with Figure 4.1. The test signal and the active power of the Reserve Unit shall be recorded.

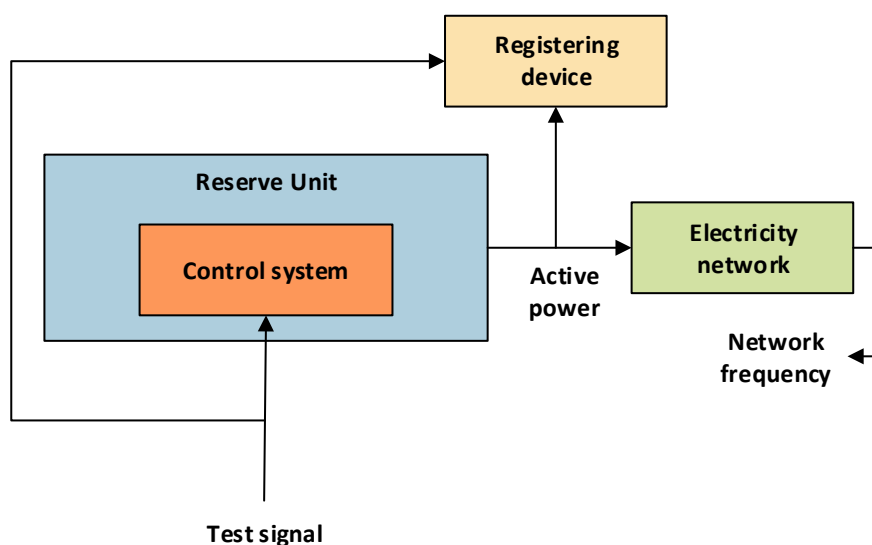

Figure 4.1 Testing arrangement of prequalification tests

The requirements and guidelines given in this document shall be followed in the execution of the prequalification tests. If the execution of the control test or its part in the manner specified is not possible due to the properties of the Reserve Unit, Balancing Service Provider and Fingrid can agree on an alternative method.

4.1 Specification of reserve capacity

The prequalification tests are used for specifying the maximum volume of the Frequency Containment Reserve for Normal Operation and/or Frequency Containment Reserve for Disturbances that the Reserve Unit can provide for the reserve market. The reserve capacities are determined at an accuracy of 0.1 MW.

4.1.1 Verification of Frequency Containment Reserve for Normal Operation

The verification of the Frequency Containment Reserve for Normal Operation is carried out by using a step response test, where frequency deviations -0.10 Hz and +0.10 Hz are fed to the measurement branch for load-frequency control. Figure 4.2 illustrates the test sequence. The power change caused by the frequency change shall be recorded for five minutes. The measurement result shall be read at three minutes. The reserve shall remain activated even after three minutes.

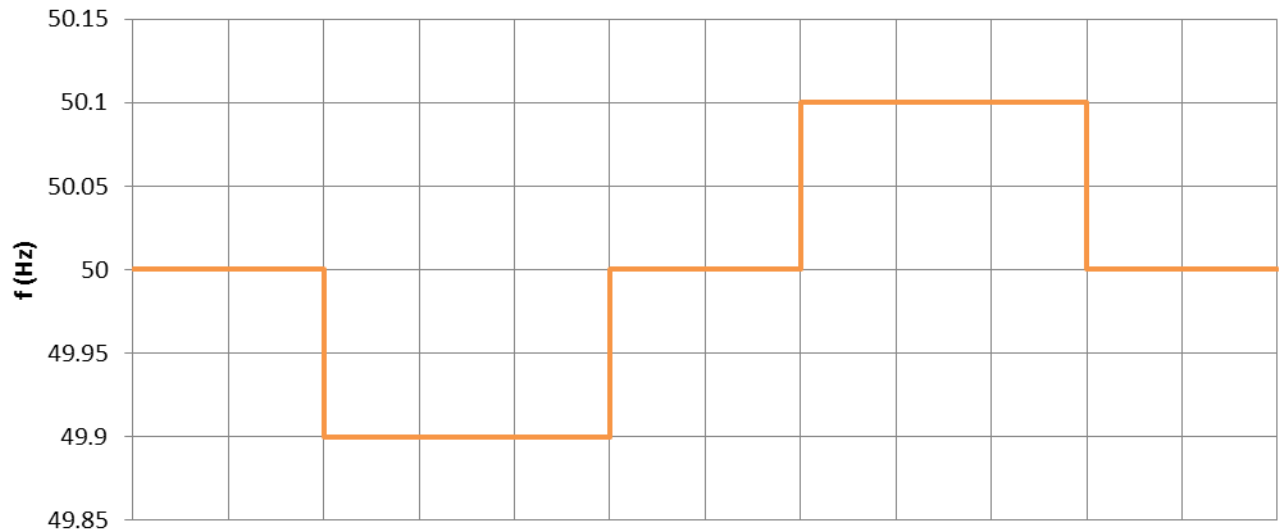

Figure 4.2 Verification of Frequency Containment Reserve for Normal Operation

The change in active power activated in three minutes shall be considered as the capacity of the Frequency Containment Reserve for Normal Operation. If the capacities activating as upward balancing and downward balancing are of a different magnitude, the smaller one of these shall be the reserve capacity.

4.1.2 Verification of Frequency Containment Reserve for Disturbances

The verification of the Frequency Containment Reserve for Disturbances is carried out by using a step response test. FCR-D up is verified using the sequence illustrated in Figure 4.3. At the start of the test, the frequency is set to 49.9 Hz by feeding a frequency deviation of -0.10 Hz to the measurement branch. When the response has stabilized, stepwise frequency changes from 49.9 Hz to 49.7 Hz and 49.5 Hz are applied, as shown in the figure. The power change caused by the frequency change shall be recorded for two minutes. The capacity of FCR-D up is specified from the power activating at 49.5 Hz. The capacity is the smaller one of the following changes in active power: the power activating in 30 seconds or the power activating in five seconds multiplied by two. The reserve capacity must also remain activated after 30 seconds. The 49.7 Hz frequency is used to verify the linearity of the control.

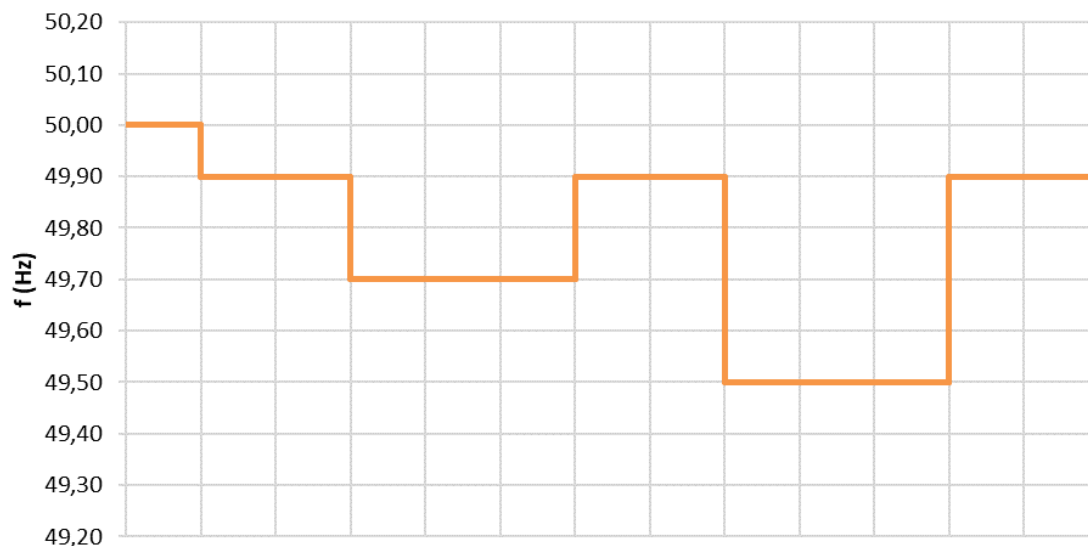

Figure 4.3 Verification of Frequency Containment Reserve for Disturbances upwards

Similarly, FCR-D down is verified using the sequence illustrated in Figure 4.4. At the start of the test, the frequency is set to 50.1 Hz by feeding a frequency deviation of 0.10 Hz to the measurement branch. When the response has stabilized, stepwise frequency changes from 50.1 Hz to 50.3 Hz and 50.5 Hz are applied, as shown in the figure. The power change caused by the frequency change shall be recorded for two minutes. The capacity of FCR-D down is specified from the power activating at 50.5 Hz. The capacity is the smaller one of the following changes in active power: the power activating in 30 seconds or the power activating in five seconds multiplied by two. The reserve capacity must also remain activated after 30 seconds. The 50.3 Hz frequency is used to verify the linearity of the control.

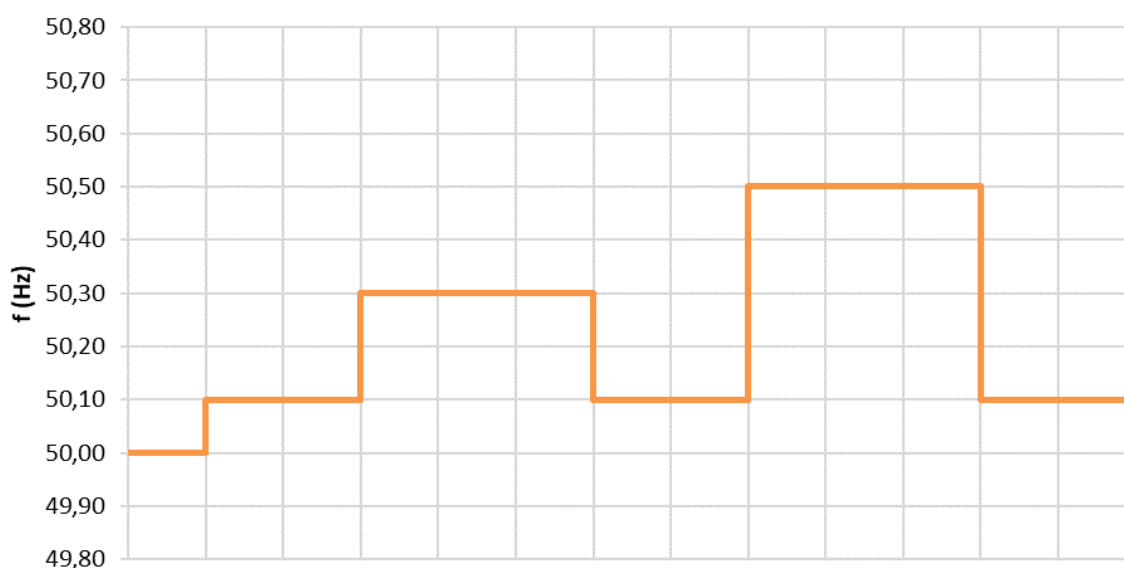

Figure 4.4 Verification of Frequency Containment Reserve for Disturbances downwards

4.2 Accuracy requirements concerning measuring and registering equipment

In the prequalification test the accuracy of the power and frequency measurements must fulfil the requirements outlined in section 3.5.

The sampling interval of the registering equipment shall be at the most 0.2 seconds so that the Frequency Containment Reserve for Normal Operation and Frequency Containment Reserve for Disturbances as well as other parameters relating to the control properties can be defined at sufficient accuracy.

4.3 Measurement of sensitivity of load-frequency control

The sensitivity of load-frequency control is the smallest frequency change to which the Reserve Unit responds so that the activating active power can be measured. It is measured in all Reserve Units that participate in the maintaining of the Frequency Containment Reserve for Normal Operation.

If it is possible to set a dead band for the control system as a parameter, the sensitivity of the control shall be tested by feeding a stepwise frequency change that is slightly bigger than the dead band, and by measuring the active power activating as a result of the frequency change for three minutes.

If a dead band has not been set, the measurement shall be carried out by feeding a stepwise frequency change to the control system and by measuring the active power activating as a result of the frequency change for three minutes. The first frequency change to be used is ± 10 mHz, after which the measurement shall be carried out, if necessary, in steps of ± 10 mHz up to a frequency deviation of ± 50 mHz.

The measurement shall be carried out using the same power levels as in the measurements of the Frequency Containment Reserve for Normal Operation and Frequency Containment Reserve for Disturbances. If different values are obtained for the dead band with different power levels, the average of the dead bands measured shall be applied to the Agreement.

4.4 Issues to be taken into account in the measurement of power plant machineries

The prequalification tests shall be carried out at three power levels:

- at the smallest power setpoint $P_{\min, \text{set}}$, at which there is a willingness to be able to offer the reserve
- at the greatest power setpoint $P_{\max, \text{set}}$, at which there is a willingness to be able to offer the reserve
- at a power setpoint existing between the powers $P_{\min, \text{set}}$ and $P_{\max, \text{set}}$.

$$P_{50\%, \text{set}} = P_{\min, \text{set}} + \frac{P_{\max, \text{set}} - P_{\min, \text{set}}}{2}$$

The Frequency Containment Reserve for Normal Operation and Frequency Containment Reserve for Disturbances is the smallest of the measurement results obtained at the above-mentioned power levels.

It shall be remembered in the measurement of the Frequency Containment Reserve for Disturbances that the Frequency Containment Reserve for Normal Operation shall also remain fully activated.

If it is not possible to carry out the control test by replacing the measurement of the frequency of the network with an artificial frequency deviation, the step response test can be carried out by changing the reference value of frequency or by adding up the stepwise frequency change to the measured frequency of the network.

4.5 Prequalification tests of aggregated Reserve Units

An aggregated Reserve Unit can be made up of individual Reserve Resources. Fingrid has a right to request real time data and history data separately of the individual resources of an aggregated unit. The rules of the participation of aggregated Reserve Units in the market have been described in document “Terms and conditions for providers of Frequency Containment Reserves (FCR)”.

Three different methods can be applied to the verification of the control capability of aggregated Reserve Units. The method of execution of the prequalification test shall be agreed upon with Fingrid in advance.

1. Testing the aggregated unit as a whole

The test signal shall be fed into the upper level control system, and the activating power shall be calculated as the sum total of the powers of all resources. Balancing Service Provider shall indicate that the aggregated unit in full fulfils the technical requirements. Adding new resources requires a prequalification of the new resources or a new prequalification of the whole Reserve Unit.

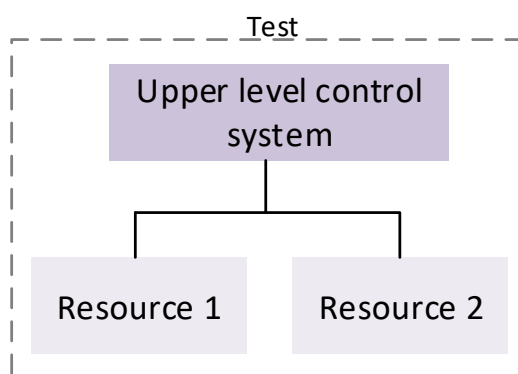

Figure 4.4 Testing of aggregated Reserve Unit as a whole

2. Testing of individual resources separately

Each resource is tested separately. Balancing Service Provider shall indicate that each aggregated resource fulfils the technical requirements independently. Balancing

Service Provider shall also indicate that the functioning of the upper level system fulfils the requirements (for example verification of data transfer delays).

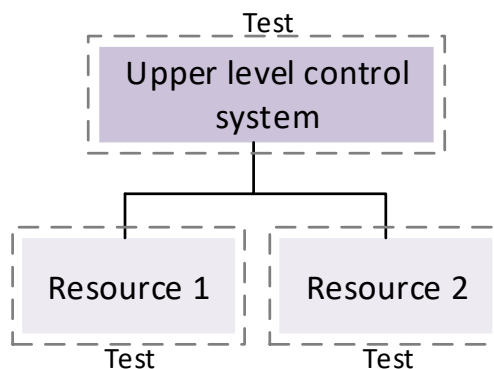

Figure 4.5 Testing of individual resources

3. Type approval

Type approval may be used for identical resources if the capacity of a single resource does not exceed 0.1 MW. The Balancing Service Provider must demonstrate that the resources operate identically. New similar resources can then be added to the aggregated Reserve Unit without prequalification tests. However, increasing the approved capacity of the Reserve Unit requires a notification to Fingrid.

4.6 Documentation of prequalification test results

A free-format prequalification test record shall be delivered of the results of a prequalification test. The record shall include the name of the Reserve Unit and the measurement date.

A graph shall be drawn of the measurement results of the Frequency Containment Reserve for Normal Operation and/or Frequency Containment Reserve for Disturbances, with the graph showing the frequency (test signal used) and active power in relation to time.

A separate graph shall be drawn of the measurement results of the sensitivity of the load-frequency control of the Frequency Containment Reserve for Normal Operation.